

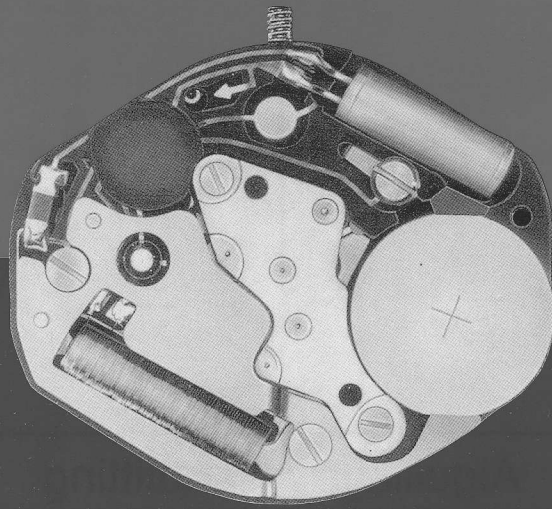

ISAQUARTZ



ISA

K63

6 ³/₄ - 8

H. 2,95



FABRIQUE D'ÉBAUCHES DE SONCEBOZ S. A.

Division électronique Isaquartz

2068 Hauterive/Neuchâtel (Suisse)
Case postale 24 – Rouges-Terres 61
Téléphone (038) 25 88 44 – Téléfax (038) 25 54 73

K63

6 3/4 - 8

Mouvement électronique, quartz 32'768 Hz. Seconde centrale, une impulsion par seconde.
Tige 2 positions. Stop seconde. Stop moteur. Moteur rotatif pas à pas.

Electronic movement, quartz 32'768 Hz. Sweep second, one impulse second.
Stem 2 positions. Stop second. Stop motor. Rotating stepping motor.

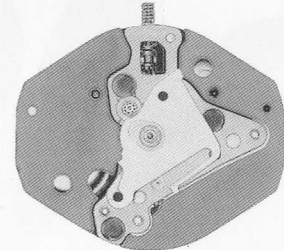
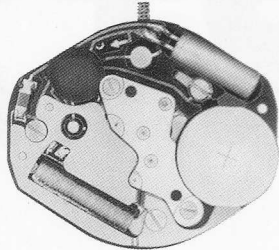

Echelle 2 : 1

- 1 : Repos - Rest
- 2 : Aiguilles + Stop moteur - Hands + Stop motor

Cage / Frame

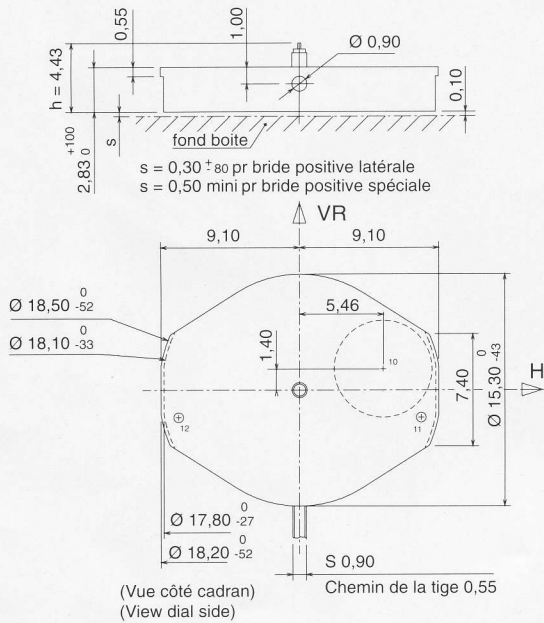

Cadran / Dial

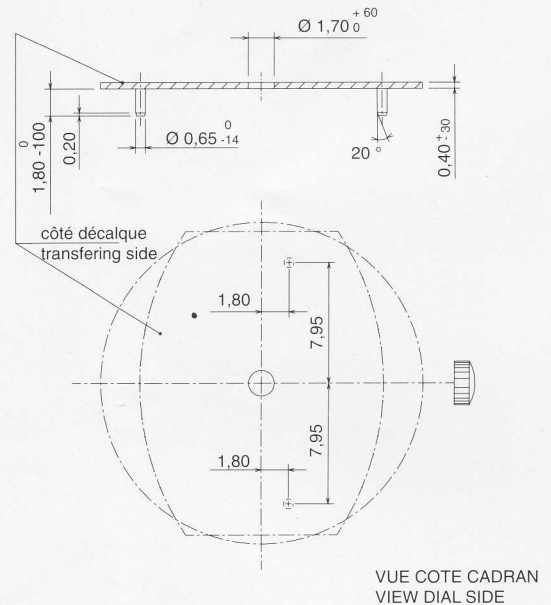

Aiguillage / Handfitting

Force de chassage des aiguilles: 2 kg max.
Strength for driving hands: 2 kg max.

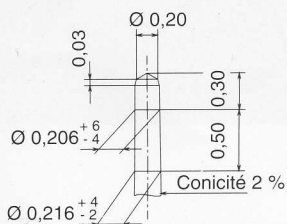

Pivot de seconde t3
Second pivot t3

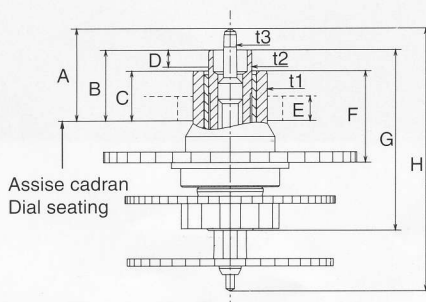

t1	Ø 1,20 ⁺⁴ ₋₂
t2	Ø 0,70 ⁺⁶ ₋₄

Hauteur aiguillage / Height Handfitting

N°	A	B	C	D	E	F	G	H
1								
2	1,6	1,25	0,90	0,25	0,4	1,49	2,94	4,27

D: hauteur du canon de l'aiguille des minutes.
Minute hand cannon height.

Aiguille de seconde / Second hand:

Balourd maxi conseillé / Maxi unbalance counseled: 0,04 µ Nm (0,4 mg cm)

Masse maxi conseillée / Maxi mass counseled: 10 mg

Aiguille de minute / Minute hand:

Balourd maxi conseillé / Maxi unbalance counseled: 0,3 µ Nm (3 mg cm)

Masse maxi conseillée / Maxi mass counseled: 10 mg

Performances

Characteristics

ALIMENTATION: pile
POWER SUPPLY: battery

1,55V Ø 6,80 x h 2,67 mm (SR 627 SW)

capacité 27 mAh
capacity

Critères Criteria	Conditions Conditions	Min.	Typ.	Max.	Unités Units
Consommation Power consumption (U = 1,55 V , T = 25 °C)			1,45	1,60	µA
Marche instantanée Instantaneous rate (U = 1,55 V , T = 25 °C)		-0,5 -1,5		+0,5 +15	S / j, d S / m, m
Plage de fonctionnement en température Operating range temperature		0		+50	°C
Résistance aux chocs Shock resistance	NIHS 91-10				
Protection aux champs magnétiques Protection against magnetic forces		1500 18,8			A/M Oe
Autonomie avec pile de: Autonomy with battery of: 27 mAh			25		mois months

Vissage et lubrification

Screwing and lubrication

Sous le module électronique
Under electronic module

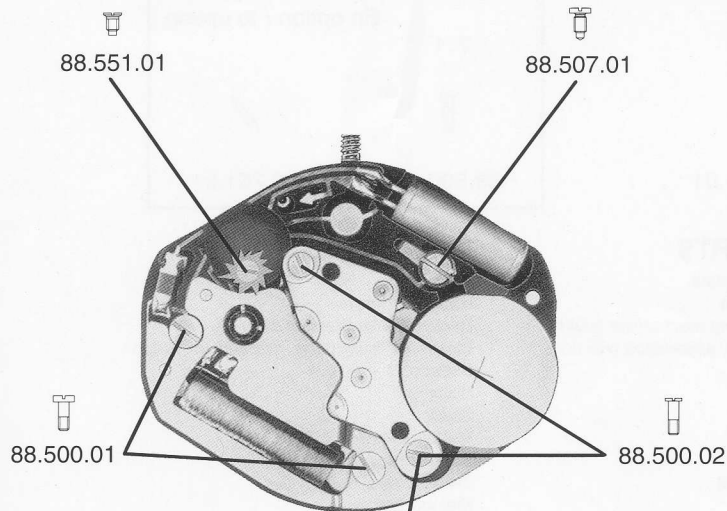

Option :

88.500.03



Huile fine
Fine oil

(Mœbius 9030)



Huile épaisse
Thick oil

(Mœbius 8200)



Graisse
Grease

(Jismaa 124)

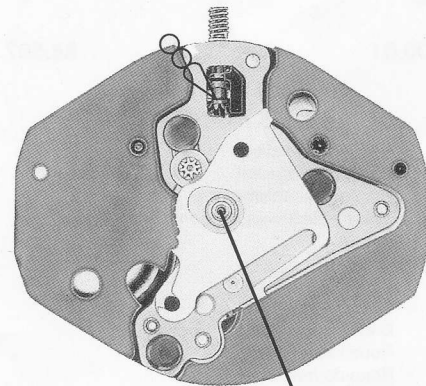

30.083.01

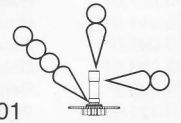

Fixation de la pile (2 possibilités)

Fastening of the battery (2 possibilities)

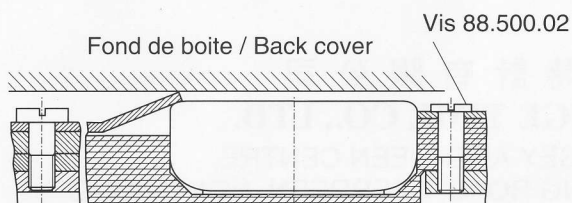

Contact positif latéral + fond de la boîte
Side positive contact + back cover

Vis 88.500.03

(remplace 1 vis 88.500.02)

Screw 88.500.03

(replaces 1 screw 88.500.02)

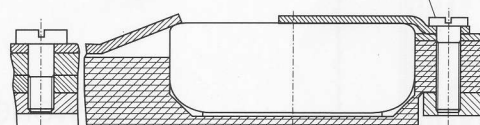

Bride positive spéciale
Upper special clamp

Fournitures / Parts

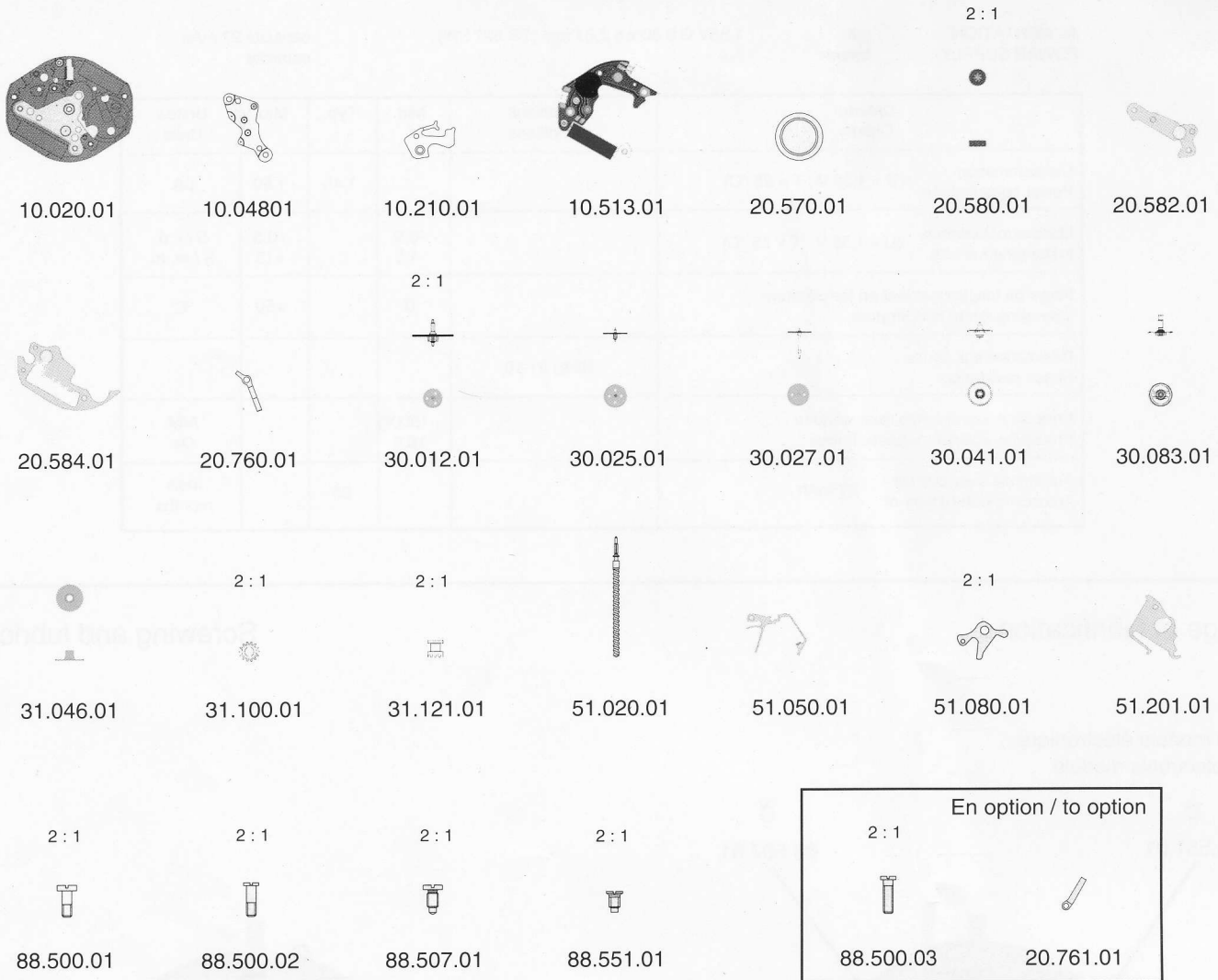

N° LISTE DES FOURNITURES

10.020.01	Platine assemblée
10.048.01	Pont de rouage fini
10.210.01	Couvre mécanisme
10.513.01	Module électronique, monté avec bobine
20.570.01	Pile
20.580.01	Rotor
20.582.01	Stator
20.584.01	Ecran magnétique
20.760.01	Bride d'alimentation
30.012.01	Roue intermédiaire
30.025.01	Roue de moyenne
30.027.01	Roue de seconde
30.041.01	Roue de minuterie
31.046.01	Roue des heures
31.083.01	Chaussée avec entraîneur
31.100.01	Renvoi
31.121.01	Pignon coulant
51.020.01	Tige de mise à l'heure
51.050.01	Bascule
51.080.01	Tirette
51.201.01	Plaquette de maintien de roue des heures
88.500.01	Vis stator (x 2)
88.500.02	Vis pont de rouage (x 2)
88.507.01	Vis bride négative (x 1)
88.551.01	Vis couvre mécanisme (x 1)

LIST OF PARTS

Assembled main plate
Train wheel bridge
Winding and setting mechanism cover
Electronic module, assembled with coil
Battery
Rotor
Stator
Magnetic screen
Power connection
Intermediate wheel
Third wheel
Second wheel
Minute wheel
Hour wheel
Cannon pinion with driver
Setting wheel
Sliding pinion
Handsetting
Jokey
Setting lever
Maintaining plate for hour wheel
Stator screw (x 2)
Train wheel bridge screw (x 2)
Power connection screw (x 1)
Mechanism cover screw (x 1)

BESTANDTEILE

Werkplatte
Räderwerbrücke
Deckplatte für Stelleinrichtung
Elektronik-Baugruppe, montiert mit Spule
Batterie
Rotor
Stator
Magnetschirm
Stromversorgungsbügel
Zwischenrad
Kleinbodenrad
Sekundenrad
Wechselrad
Stundenrad
Minutenrohr mit Mitnehmer
Zeigerstellrad
Kupplungstrieb
Stellwelle
Kupplungstriebhebel
Winkelhebel
Halteplatte für Stundenrad
Statorschraube (x 2)
Brückenschraube (x 2)
Stromversorgungsbügelsschraube (x 1)
Deckplattenschraube (x 1)

En option / to option

20.761.01	Bride positive spéciale
88.500.03	Vis bride positive spéciale (x 1)

Special battery clamp
Special positive bridle screw (x 1)

Spezial Batteriehaltefeder positiv
Schraube für Spezial Batteriehaltefeder positiv (x 1)



超級時計有限公司
PRESTIGE TIME CO., LTD.

5-6/F., CASEY ABERDEEN CENTRE,
20 WONG CHUK HANG ROAD, ABERDEEN, HONG KONG.
TEL : (852) 2552 2633 FAX : (852) 2552 3181